

Integration for CA Spectrum® Gateway with BMC Remedy

agility
made possible™



What it does

Integration for CA Spectrum® Gateway with BMC Remedy enables bidirectional communication between the CA Spectrum® Infrastructure Manager and the BMC Remedy system to provide integration of alarm and incident management between both applications.

Benefits that deliver value

Integration for CA Spectrum Gateway with BMC Remedy:

- Delivers time-saving workflow automation to accelerate service restoration
- Improves communications between CA Spectrum and the BMC Remedy system by supporting high level functions that allow users to:
 - Generate manual or automatic incident reports
 - View an incident based on pre-set thresholds
 - Filter alarms to increase response time

How it works

The solution utilizes the CA Process Automation Gateway to enable information flow between CA Spectrum Infrastructure Manager and BMC Remedy as illustrated to the right:

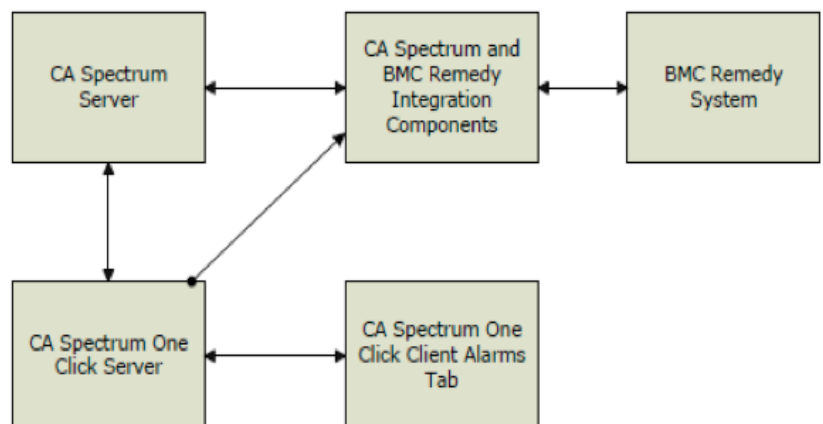

Technical prerequisites

Integration for CA Spectrum Gateway with BMC Remedy supports the following product versions:

- CA Spectrum Infrastructure Manager r9.0 SP1 or higher (r9.0.1 or higher)
- BMC Remedy (for ITIL or non-ITIL based Remedy HelpDesk versions):
 - BMC Remedy AR System r6.3, r7.0.x, 7.1 with non-ITIL based Remedy HelpDesk
 - BMC Remedy AR System r7.0.x, 7.1 with ITIL based Remedy Incident Management